

Installation, Operating, Maintenance
and After Sales Manual.

WHISPA III® 5000, 9000 & 12000 RCU

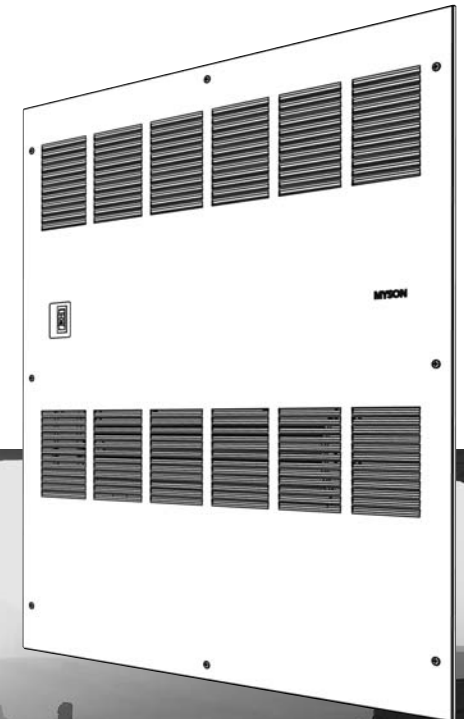

heatingthroughinnovation.

heatingthroughinnovation.

Product Serial Number:

--	--	--	--	--	--	--

Installation Date:

--

Part Number: 1371051
Issue 1

01.06.2009 ISSUE 1



Tested to UL & CSA Standards

Contents

1.0	General Information	03
2.0	Heating System Design	03
3.0	Selection and Sizing for Heating	03
4.0	Location	03
5.0	Preparation	04
6.0	Electrical Connection	05
7.0	Water Connection	06
8.0	Technical Data	08
9.0	Operating Instructions	09
10.0	Troubleshooting	10
11.0	Maintenance	11

1.0 General Information

- This MYSON WHISPA III® recessed commercial unit (RCU) is designed for recessed wall applications where the use of surface mounted units would not be appropriate. All units have a one piece low profile front cover.
- WHISPA III® RCU fan convectors are designed to be used with mono-flo Tees from a series loop, on a two pipe system, or as a stand alone zone.
- WHISPA III® RCU fan convectors are available in three sizes, and before proceeding with the installation the heating system design must be considered and the unit correctly selected to meet the heat loss requirement of the room.
- WHISPA III® RCU fan convectors are supplied with a fan speed selector switch mounted on the front of the unit.
- WHISPA III® RCU fan convectors are supplied with built in ½" compression shut off valves for both the supply and return.
- WHISPA III® RCU fan convectors are supplied with high volume purge valve - air vents.
- WHISPA III® RCU fan convectors are supplied with an integral combi - zone control and flow control valve, with a factory fitted insert set to give 1 GPM. The flow rate through the unit will not exceed this value, however, other inserts of 2 GPM or 3 GPM can be fitted by the installer to give higher flow rates.
- A low limit thermostat prevents the fan from operating if the water temperature in the unit is below 110°F
- WHISPA III® RCU fan convectors are not designed for use with steam.
- A 24V room thermostat, On – Off or set back type, can be wired to this unit to give room temperature control.
- A time control can be wired to WHISPA III RCU fan convectors to provide occasional coil purging flow through the coil if considered necessary.
- All waterways are of copper. No lead brazing materials are used to assemble this unit.

2.0 Heating System Design

- The WHISPA III® RCU can be fitted on a series loop with mono-flo or venturi Tees, on a two pipe system or as a stand alone zone.
- For optimum fan convector performance the system must be capable of providing sufficient hot water through the heat exchanger. This means that:
1. Care must be taken in sizing both the pump and piping. The minimum pipe size from the boiler to the fan convector must be ½" copper tube.
 2. Where the WHISPA III® RCU is fitted on to a system with other emitters, mono-flo Tees or diverter Tees should be used to provide adequate water flow.
 3. The system water must be above 110°F for fan to switch on, and best results the mean water temperature should not be below 140°F.
 4. Optimum performance will require effective balancing of the whole system.
 5. The WHISPA III® RCU should not be used to replace a radiator in an existing system unless an adequate flow of water can be guaranteed through the unit.
 6. The loop must be pumped. WHISPA III® RCU fan convectors are not suitable for gravity circulation systems.

3.0 Selection and Sizing for Heating

- Heat output performance figures for the three sizes of WHISPA III® RCU fan convectors are given in the Technical Data section of this manual.
- Since WHISPA III® RCU fan convectors are supplied with fan speed control, it is important to size the unit to match the calculated heat loss requirements of the room with the unit operating at the low fan speed (I).
- The higher fan speed can then be used for more rapid heating from cold in extreme conditions.
- When establishing the temperature difference, i.e. entering water to room temperature, allowance should be made for temperature drop in the system. It is the water temperature at the fan convector that dictates the output.

4.0 Location

- The WHISPA III® RCU fan convector is designed for recessed wall applications.
- WHISPA III® RCU fan convectors are designed for normal 2" x 4" stud wall framing, with 5/16" thick cover extending beyond the wall surface once installed.
- The size of the opening required to be cut for installation is shown in Fig 1.

1.0
2.0
3.0
4.0

5.0 Preparation

Before proceeding with the installation, unpack the carton contents and check against the checklist below:

1. WHISPA III® RCU.
 2. Instruction manual.
 3. Front cover.
 4. Screw fixing kit.
- The WHISPA III® RCU fan convector is designed so that the piping and wiring connections are made within the cabinet of the unit itself. The installer should inspect the unit and note that the ½" piping should enter on the lower right corner of the unit and the 110V AC wiring for the unit enters on the lower left hand corner of the unit, see Fig 2.
 - Prepare the opening in the wall to accept the unit as shown in Fig. 1. Depending on the wall framing layout, the 9,000 and 12,000 models may require re-framing of the opening to ensure proper support.
 - Do not fit the unit at this stage.

Dimensions of opening to be cut in wall

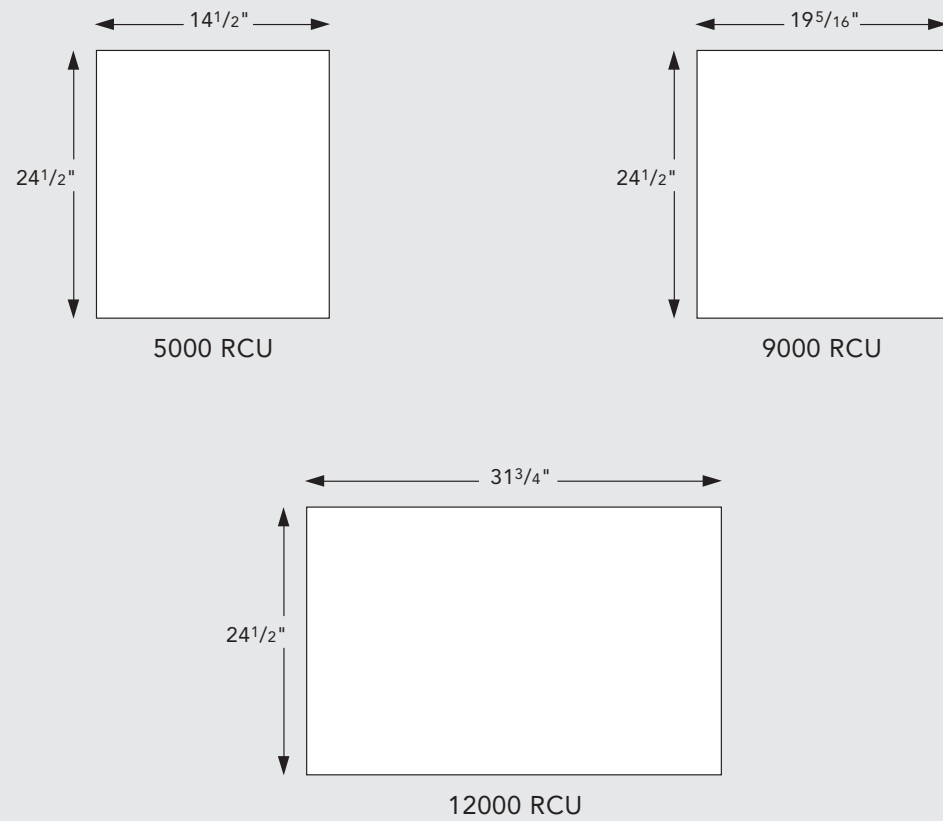

Fig. 1

Note: All models require a depth of at least 3 1/2".

6.0 Electrical Connection

WARNING: This appliance must be grounded.

- The electrical installation must comply with local or national wiring regulations.
- A hole is provided at the lower left hand corner of the unit for a BX or Romex connector.
- Make electrical connection to the terminal block:
 - Black Lead – Hot 110V 60Hz
 - White lead – Neutral
 - Green – Ground

Do not energize the electrical supply until the remaining stages of the installation have been completed.

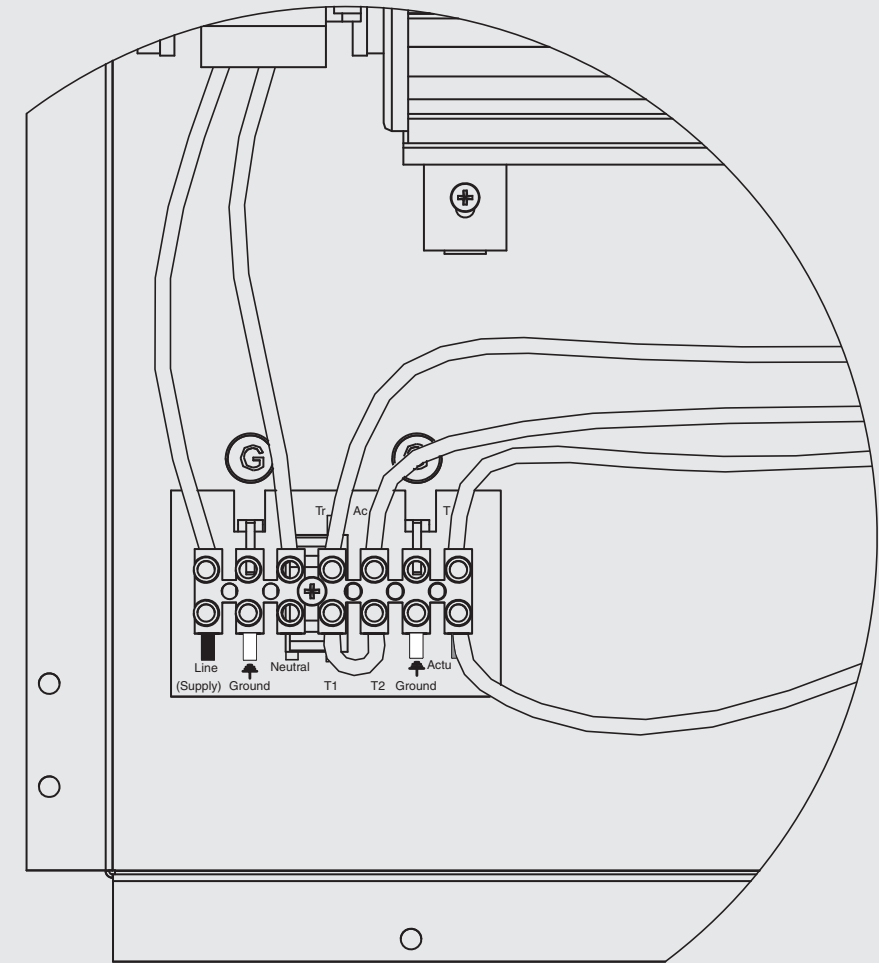
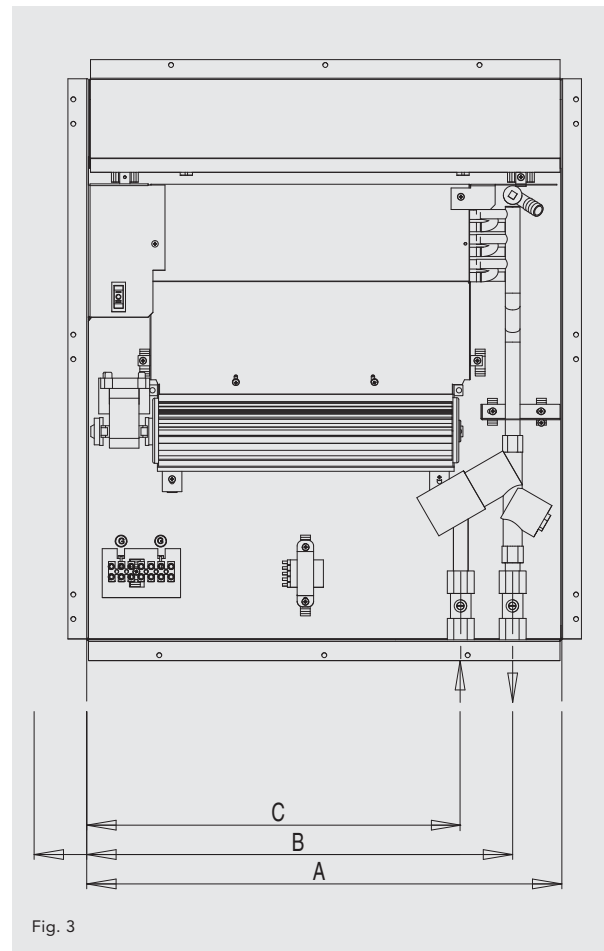

Fig. 2

7.0 Water Connection

- This unit is supplied with ½" compression isolating valves. Bring ½" copper tubing to the unit and make the compression joints. Connect the supply to the left hand isolating valve. This is necessary to allow proper venting and purging of the fan convactor.
- The WHISPA III® RCU fan convector is fitted with a flow regulator set at 1 GPM maximum. If another pre-set maximum flowrate is required then the insert can be changed at this stage. Unscrew the insert cap on the flow control valve. Remove the insert and replace with the alternative. Replace cap and tighten.
- Many installers are now beginning to use flexible heat tubing to make these connections. Ensure prior to use that the tubing selected is appropriate for the water temperature to be supplied.
- Once the connections to the heating loop are complete, the unit must be vented using the air purge valve. Fit a length of hose to the purge valve so that any water from the heating circuit escaping during the venting process can be directed to waste, see Fig 3. Open the air purge valve by loosening the screw.
- Open the left hand valve at the bottom of the unit and purge the unit for 1-2 minutes. Close the LH valve and then open the RH valve. Switch on the supply to the unit and energise the flow control valve by switching on the room thermostat. Purge the air from the unit, then close the RH valve and switch off the room thermostat. Close the purge valve, disconnect the hose and open both valves.
- When the operation of the unit has been tested, align and secure the front cover (eight screws), see Fig 4.



Model	Dimensions (in)		
	A	B	C
5000	14 3/16	13 5/8	10 3/8
7000	19 1/8	17 1/8	15 1/16
9000	31 5/8	29 1/4	27 1/8

Note: dimensions in inches.

7.0 Water Connection (continued...)

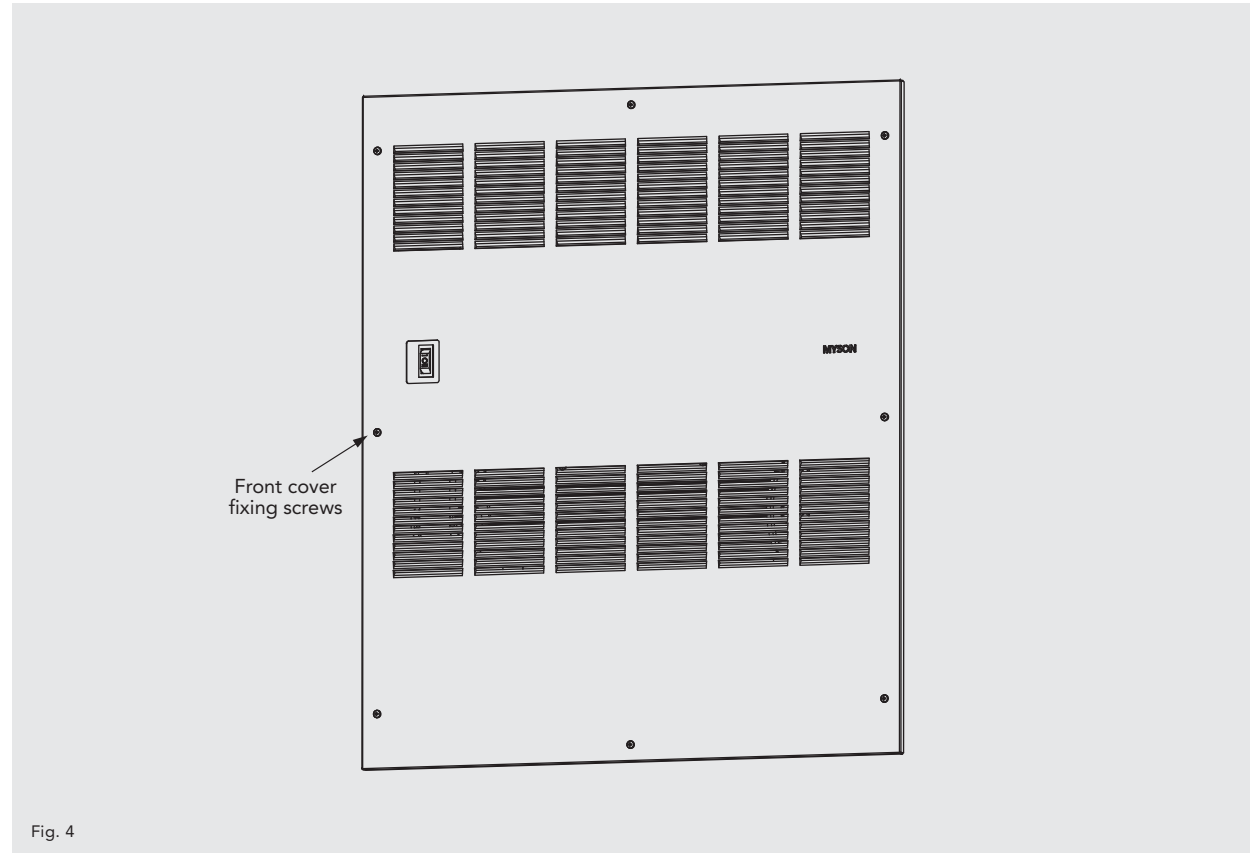

8.0 Technical Data

Heating Performance Data

Model	Fan Setting	Flowrate (gpm)	Heat Output (Btu/h)									
			Entering Water Temperature (°F), Entering Air Temperature (65°F)									
			110	120	130	140	150	160	170	180	190	200
5000 RCU	High (II)	3	2040	2516	2997	3480	3967	4457	4949	5443	5939	6437
	Low (I)		1749	2096	2437	2773	3104	3432	3756	4078	4397	4713
	High (II)	1	1795	2214	2637	3063	3491	3922	4355	4790	5226	5664
	Low (I)		1539	1844	2144	2440	2732	3020	3306	3589	3869	4147
9000 RCU	High (II)	3	3759	4629	5504	6385	7271	8160	9053	9949	10848	11750
	Low (I)		3266	3916	4556	5185	5807	6422	7031	7634	8233	8827
	High (II)	1	3308	4073	4844	5619	6398	7181	7967	8755	9546	10340
	Low (I)		2874	3446	4009	4563	5110	5652	6187	6718	7245	7767
12000 RCU	High (II)	3	4369	5437	6524	7623	8739	9866	11003	12149	13307	14472
	Low (I)		3019	3733	4454	5180	5911	6649	7389	8136	8887	9640
	High (II)	1	3845	4785	5740	6709	7690	8682	9682	10692	11709	12734
	Low (I)		2657	3284	3918	4558	5202	5851	6504	7160	7819	8482

Maximum inlet water temperature 200°F
 Heat outputs tested in accordance with BS 4856 Part 1
 Electrical supply: 110V 60Hz
 Max working pressure: 145psi
 Water connections: 1/2" Sweat

Approximate Hydraulic Resistance through Units

g/min	ft wg		
	5000	9000	12000
3	4.90	6.89	13.1
1	0.75	1.07	1.4

Weight, Water Content and Motor Power

Model	Motor Power (W)	Water Content (fl oz)	Unit Weight (lbs)
5000	25	5	9.5
9000	40	11.5	14.2
12000	62	18.9	19

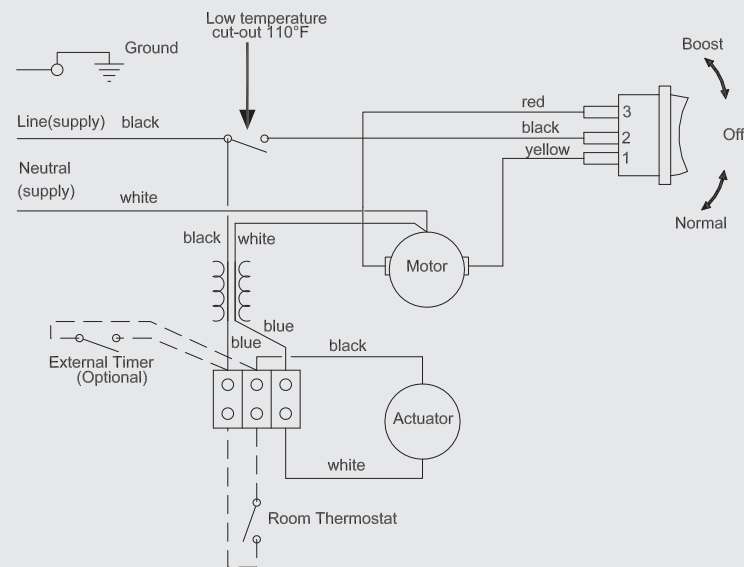

Fig. 5 Wiring diagram

9.0 Operating Instructions

WHISPA III® RCU fan convectors are controlled by the switch on the front of the unit.

Ensure the electricity supply is switched on.

Heating Mode

The fan will only operate when

- The central heating boiler is on
- The pump is running
- The system water temperature is greater than 110°F.
- The room thermostat linked to the unit is switched on.

Ensure boiler is on, and set timer, boiler controls and room thermostats as necessary.

- Set the fan speed switch to the LOW (I) position.
- The unit will now run on low fan speed. For satisfactory operation the mean water temperature should not be below 140°F.

Temperature Control

The room thermostat setting should be adjusted to obtain the desired temperature.

The fan speed can be set to boost by switching the fan speed switch to II.

A low speed setting is recommended for normal operation with the higher speeds for boost heating when required.

Low Limit Operation

The low limit thermostat fitted to the WHISPA III® RCU will ensure that the fan stops after the heating system is switched off and the water flow stops. If left in an operating position the unit will automatically restart when the heating system is reheated.

Off Position

Set the fan speed selector switch to the off position.

Operating Sequence

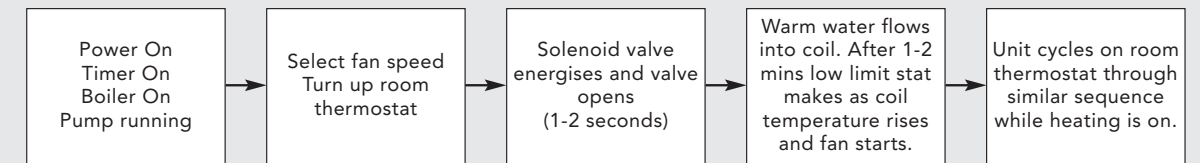

10.0 Troubleshooting

Once installed, this fan convector becomes an integral part of the heating system that will also include boiler, pump, other emitters such as radiators and fan convectors, and a number of heating controls depending on system complexity. An apparent problem with this unit may be the result of system controls being incorrectly set, and can be solved easily without calling out your installer or MYSON. Before calling out your installer or MYSON, please carry out the checklist below.

Problem	Possible Causes	Remedy
Heating Mode - No Fan	Room thermostat not calling for heat	Turn up room thermostat
	Unit not switched on at breaker panel	Switch on breaker
	Breaker tripped at panel	Check all wiring, reset breaker
	Water temperature reaching unit below 110°F	Check boiler - Programmer ON Boiler ON and set to high Circulating pump running Note: Operation of fan convector can be checked by switching to summer setting
Heating Mode poor heating performance and/or unit cycles on low limit thermostat	Low water temperature to unit	Turn up boiler thermostat
	Poor water flow	Vent air from heating system

If the fan convector is still faulty after checking the above, call your installer or MYSON.

Common Installation Faults

For optimum performance, this unit must be correctly sized to match the heat loss requirements of the space it is required to heat, and the heating system must be correctly designed to provide adequate flow of hot water to the unit (see section 2). If the recommendations in section 2 are not followed problems may arise as detailed below.

Problem	Possible Causes
Poor heating performance	Unit incorrectly sized for heat loss of room
Poor heating performance (unit may cycle on low limit thermostat)	Boiler thermostat set too low
	Lack of flow to fan convector - Pump set on low setting Isolating valves not fully open System incorrectly balanced with unit starved of hot water flow Pipe sizing to unit too small

Other Faults

Problem	Possible Causes	Remedy
No flow through unit, and fan not operating	Solenoid valve not energised	Check room thermostat set correctly and functioning Check transformer output 24V
	Solenoid valve not opening	Check 24V actuator

11.0 Maintenance

Before undertaking any maintenance activity isolate the electrical supply. This should involve internal cleaning of the heat exchanger using a soft brush or vacuum cleaner, taking care not to damage the fan or heat exchanger.

Maintenance should be restricted to occasional removal of dust and lint around the front cover plate. The unit should be serviced periodically by a competent person.

Spares List

Description	Part Number	Quantity
Motor / Fan Assembly WHISPA III® 5000 RCU	7100088	1
Motor / Fan Assembly WHISPA III® 9000 RCU	7100090	1
Motor / Fan Assembly WHISPA III® 12000 RCU	TBA	1
Switch, 3 way	1300025	1
Low Limit Thermostat	1260007	1
Cover plate Whispa III 5000 RCU	TBA	1
Cover plate Whispa III 9000 RCU	TBA	1
Cover plate Whispa III 12000 RCU	TBA	1
24V Actuator	TBA	1
Transformer	TBA	1